

user manual v1.1

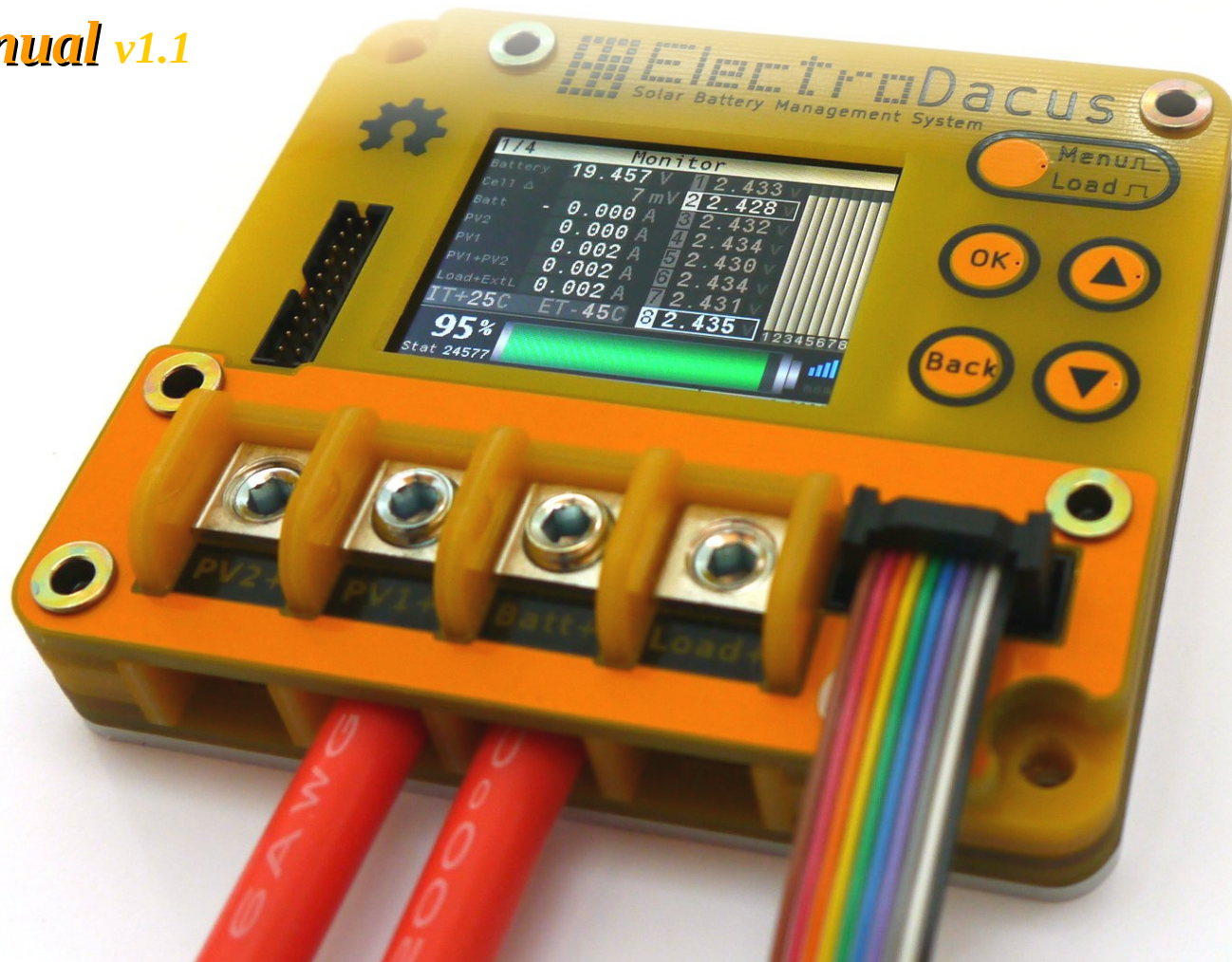

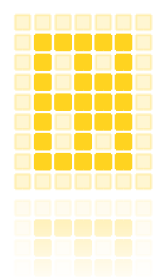
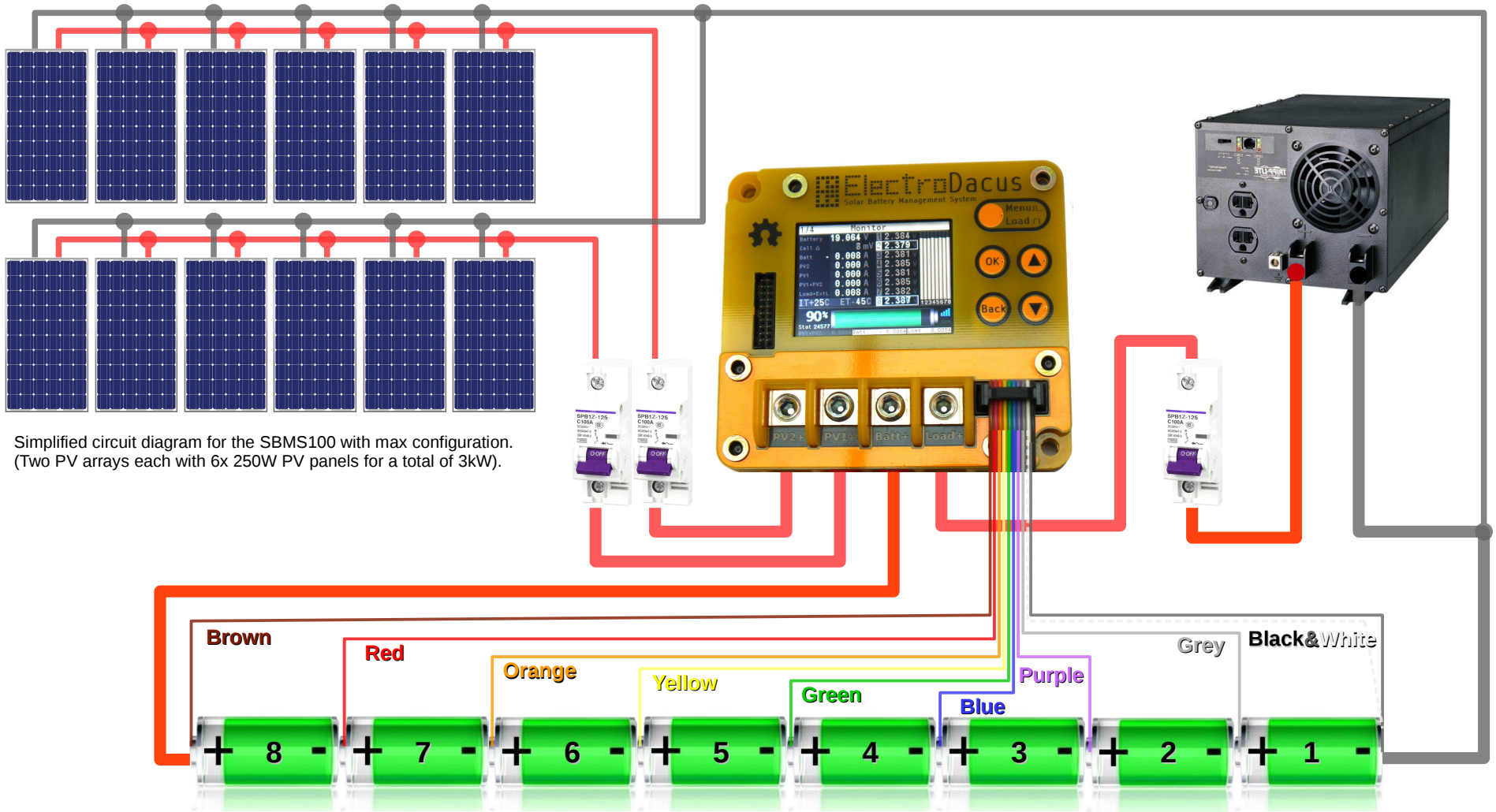

Table of contents

<i>Simplified diagram</i>	3
<i>Specifications</i>	4
<i>1. Install instructions</i>	5
<i>2. Thermal management</i>	9
<i>3. Cable selection</i>	11
<i>4. External Load</i>	13
<i>5. Battery temperature</i>	15
<i>6. The 20pin connector</i>	16
<i>7. Selecting the battery and PV panels</i>	17
<i>8. WiFi</i>	19
<i>9. Internal data logging</i>	21
<i>10. User interface</i>	24
<i>Schematic</i>	42



Simplified circuit diagram for the SBMS100 with max configuration.
(Two PV arrays each with 6x 250W PV panels for a total of 3kW).

Specification

Battery type	any type of Lithium cells and Supercapacitors
Number of cells	3 to 8 cells
Battery voltage limits (min/max)	8V to 32V
Battery/PV recommendation 12V	4 cell LiFePO4 / 32 or 36 cells PV panel
Battery/PV recommendation 24V	8 cell LiFePO4 / 60 cells PV panels
Max PV Open Circuit voltage	47V (mono or polycrystalline panels with up to 72 cells)
Dual PV input	PV1+ and PV2+ with separate current measurement and ideal diode
PV1 or PV2 max current	SBMS60 (72A) / SBMS100 (72A)
PV1 + PV2 max current	SBMS60 (72A) / SBMS100 (120A)
Load+ overcurrent limit	SBMS60 (72A) / SBMS100 (120A) (up to 500A possible with ext current shunt)
Load+ short circuit limit * (see cable selection 3.2)	SBMS60 (1000A) / SBMS100 (2000A)
Cell balancing current	max 200mA
Power terminal max wire size / recommended	35mm² (#2 AWG) / 16mm² (#6 AWG) 200C silicone
Battery temperature sensor	Thermistor (optional)
20pin connector	Includes Ext IO, 16bit ADC, external current shunt input 500A max
Data logging to internal Flash memory	128Mbit (16Mbyte) 2 minute interval for one year of data
WiFi	WiFi used for remote monitoring (SBMS acts as AP)
Display	2.2" Color LCD 320x240
Weight	255g
Dimensions	100mm x 90mm x 26mm
Self consumption	250mW to 700mW (WiFi and Backlight ON)
Max TDP	SBMS100 (22W) / SBMS60 (14W)

1 Install Instructions

**before starting with electrical installation take a look at the [thermal management](#) (the SBMS needs a heatsink in most cases)*

Step 1

Connect the Batt+ power connector to battery positive terminal with a max 2m of 16mm² (#6AWG) flexible copper wire with 200°C silicone insulation (check [page 11](#) for more details about the recommended cable).

Make sure this is the first connected and the last to be removed.

Step 2

Connect the 10pin monitor and balancing cable. Make sure this is the second one to be connected after Batt+ and **never disconnect while anything else is connected except for Batt+**. (see details on [page 3](#) or Parameter Settings on how this has to be connected to individual cells).

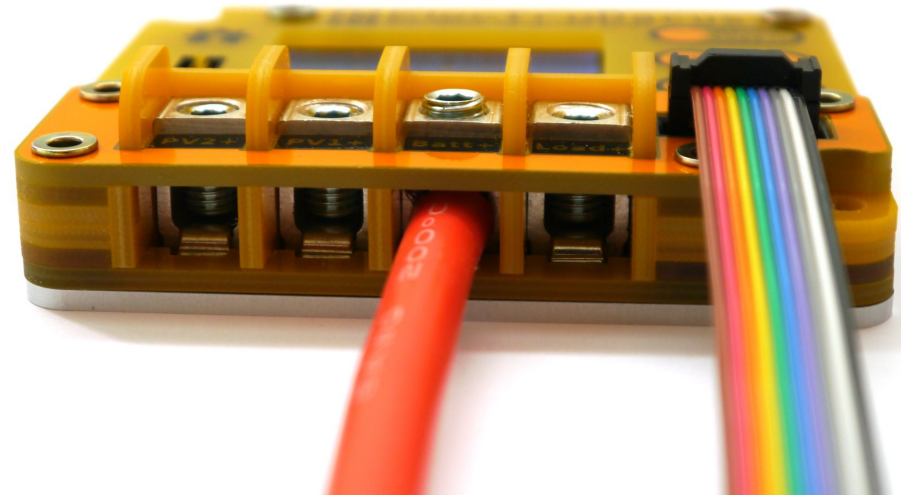

Step 3

Go to Parameter Settings menu and select the type of cell, number of cells and battery capacity then push Store Parameters button to save data to SBMS. Then remove the 10pin connector and reconnect for the new stored parameters to be accepted.

*you need to be connected to battery to Store Parameters it will not work on USB power since ISL94203 is not powered.

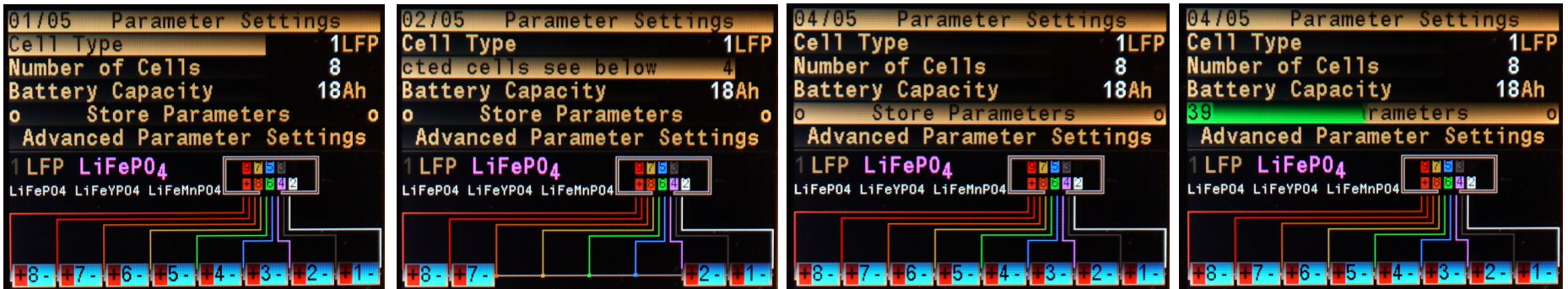

Step 4

Go to monitoring menu page 3 and push OK button then a small sub menu will be displayed in the top left corner. Use down key to select Load OFF and then push OK to enable this.

You should see CFET and DFET flags change state from highlighted to not being highlighted meaning that load+, PV1 and PV2 are disconnected internally.

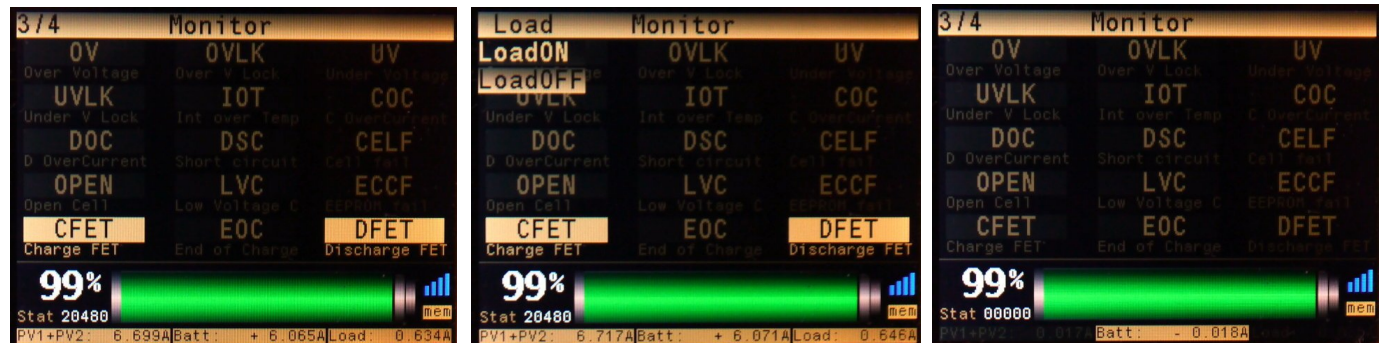

Step 5

Connect Load+ using the same type of cable mentioned in [step1](#) to a 125A circuit breaker in OFF position and from there to your load.

**Make sure the cable resistance is adequate to protect the SBMS mosfet's see [cable selection 3.2](#)*



Step 6

Connect the PV1 and or PV2 to your PV array to appropriate size circuit breaker in OFF position.

See the [page 16](#) for the type of PV panels recommended based on the number of cells and battery voltage.

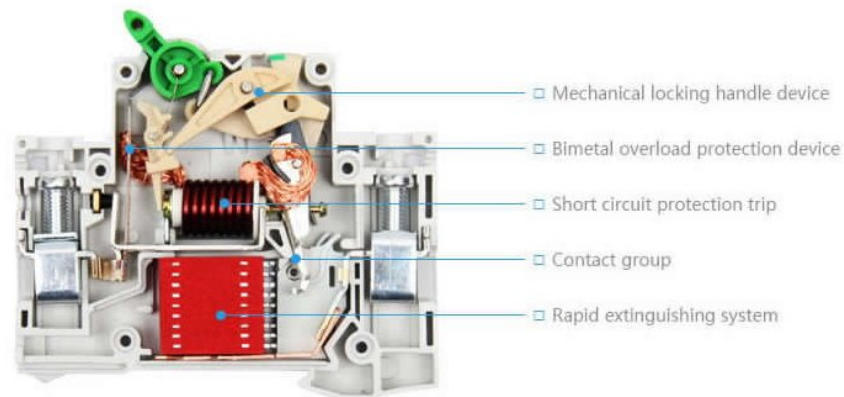

Step 7

Switch the Load and PV breakers to ON position and then go again to page 3 of the monitoring menu and select Load ON this time. The CFET and DFET should be highlighted and the Load should now have power also the PV1 and PV2 should provide charging current.

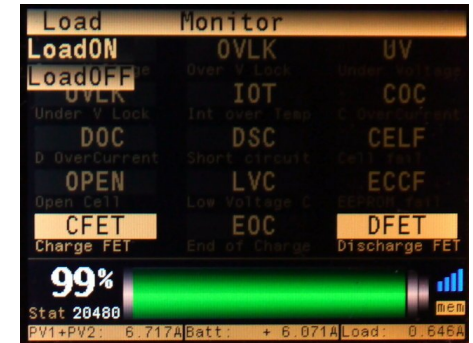

Step 8

Check the first page of the Monitoring Menu to see if all works correctly and you are done. **Make sure you follow the install procedure in reverse when you want to remove the SBMS.** Never remove the Batt+ or 10pin cell monitoring connector while PV1, PV2 or Load+ are connected.

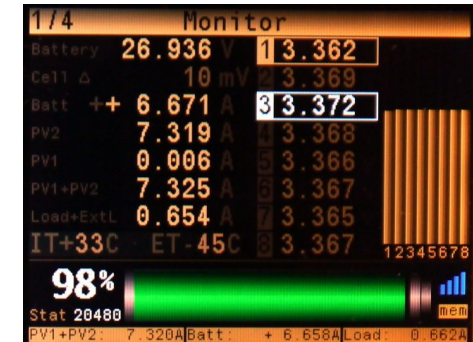

2 Thermal Management

The SBMS60 and SBMS100 will need to be mounted on an appropriate size heatsink able to dissipate the max TDP (Total Dissipated Power) that is as high as 22W for SBMS100 and 14W for the SBMS60 at full load (charge and discharge at the same time). The SBMS has two (5mm) mounting holes as you see in the drawing below.

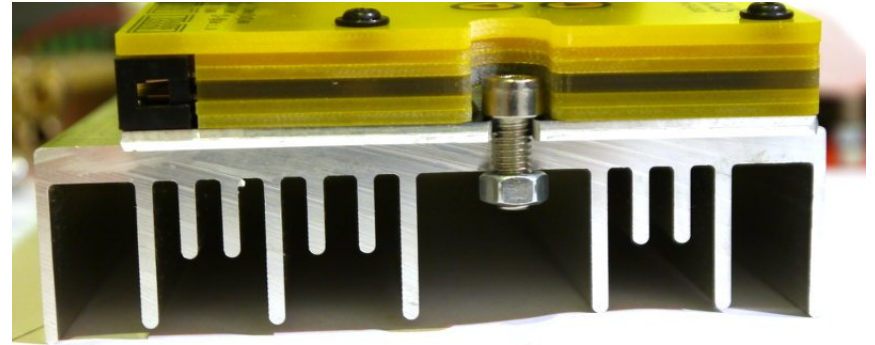
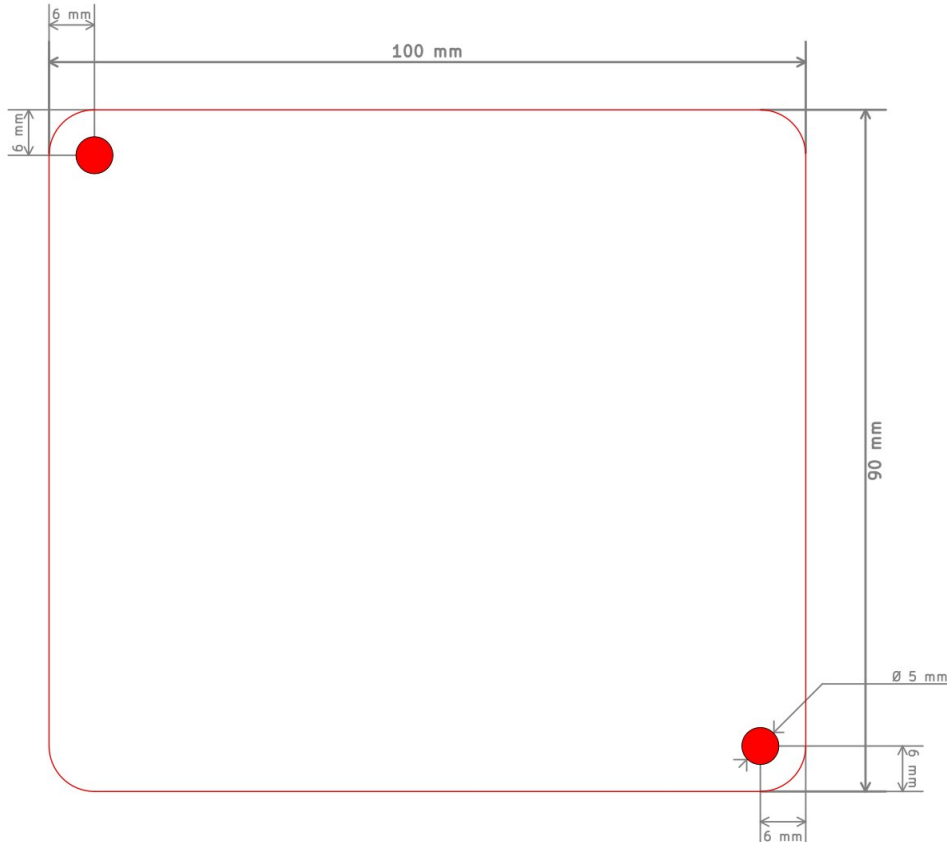

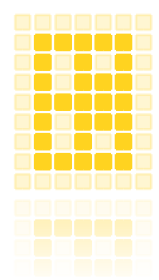

*If size and weight is of great concern in your installation a low speed fan can be used to cool the back of the SBMS.
If SBMS is not used with full configuration then a smaller heatsink can be used or even no heatsink at all.*

You can use the simple formula below to calculate the TDP.

$$TDP[W] = I[A] \times I[A] \times R[\Omega]$$

For example you need to know the R for Load+ and PV1/PV2. Load+ resistance path on SBMS100 is 1m Ω and SBMS60 is 1,5m Ω where PVx input on SBMS100 is 2,4m Ω and on SBMS60 is 3m Ω .

For max configuration on SBMS100 you have:

on Load+ $TDP = 100A \times 100A \times 0,001\Omega = 10W$

on PVx $TDP = 50A \times 50A \times 0,0024\Omega = 6W$

So total 10W + 6W + 6W = 22W on full load SBMS100

**as an example an aluminium flat plate of at least 3mm thickness and 20 x 20cm in size should be able to dissipate the 22W (of course the larger the heatsink area the better).*

The SBMS100 without any heatsink or fan can at most dissipate 4W to 5W so below is an example with lower power to allow this.

Example SBMS100 with max 40A load and 24A on each PV

on Load+ $TDP = 40A \times 40A \times 0,001\Omega = 1,6W$

on PVx $TDP = 24A \times 24A \times 0,0024\Omega = 1,38W$

Total 1,6W + 1,38W + 1,38W = 4,36W

So 40A load and 48A charging is around max supported by SBMS100 without being mounted on a heatsink.

The SBMS has an internal 10k thermistor installed on the power board and will measure and display the temperature of that board. If temperature exceeds +60°C the charging and discharging will be turned off and only turn on the charging and discharging when temperature drops below +50°C.

3.1 Cable Selection

SBMS requires flexible copper cables. For full load configuration I recommend using high quality 16mm² (sold as #6 AWG even if is much closer to #5 AWG) flexible tinned copper cable with 3200 strands of 0,08mm and 200°C silicone insulation.

I measured 1,125mΩ/m for this cable and you will want to **keep the resistance of cable between battery positive terminal and SBMS Batt+ connector below 2,5 mΩ** so around 2m max is recommended for this particular cable.

Here is a link to a google+ post I made about this cable <https://plus.google.com/+electrodacus/posts/ZNAq2ks9Pnv>

No fuse or breaker is allowed between Batt+ and battery positive terminal. Use the same cable between Load+ and a DC circuit breaker.

The same cable can be also used between PVx and a DC circuit breaker.

The circuit breakers on PVx and Load+ will allow for a way to manually disconnect the circuit and offer redundant overcurrent protection.

When you connect the cable to the SBMS power connectors please do not use too much torque. Since you will probably using a 4mm hex allen key the force pushing on the cable will be multiplied 628 times even with just a 10cm long key.

Excessive force can break the connectors from the PCB.

**please read the next page also it contains important information about cable selection.*

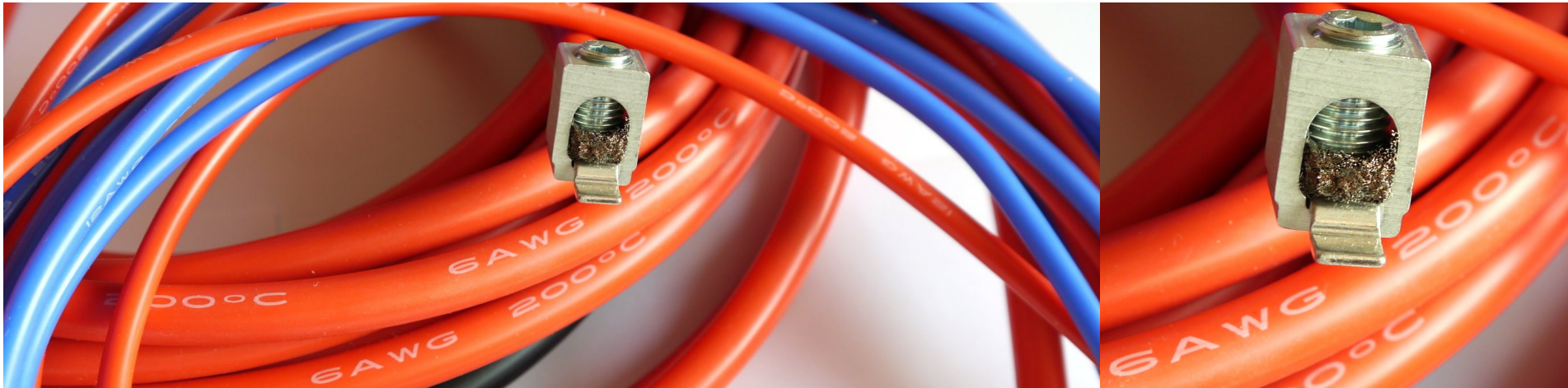

3.2 Cable Selection (max short circuit current)

Most large capacity Lithium cells have very small internal resistance so battery can output **large currents that can damage the Load mosfet's**. The only thing that will limit the current when connecting a large capacitive load like an large inverter or large DC-DC converter is the short circuit resistance that as shown in the diagram below is made out of 3 components.

First is battery internal resistance second is the SBMS Batt+ to Load+ internal resistance and last is the resistance of the cables. Battery and SBMS will have a fixed resistance so to reduce current you can only change the cable resistance.

I will use an example close to worst case with 8s 400A Winston cells just 0.3mohm for each cell fully charged around 27V and SBMS100.

To limit current to 2000A max for SBMS100 you need this total resistance

$$27V/2000A = 13.5mohm$$

Based on the simplified diagram below you get this:

$$R1+R2 = 13.5mohm - 2.4mohm - 2mohm - 1mohm = 8.1mohm$$

R1+R2 in this example needs to be minimum 8.1mohm and using the same 16mm2 cable that has 1.125mohm/m resistance you will need:

$8.1mohm / 1.125mohm = 7.2m$ of cable for R1+R2 can be split in any way maybe 3m for R1 and 4.2m for R2

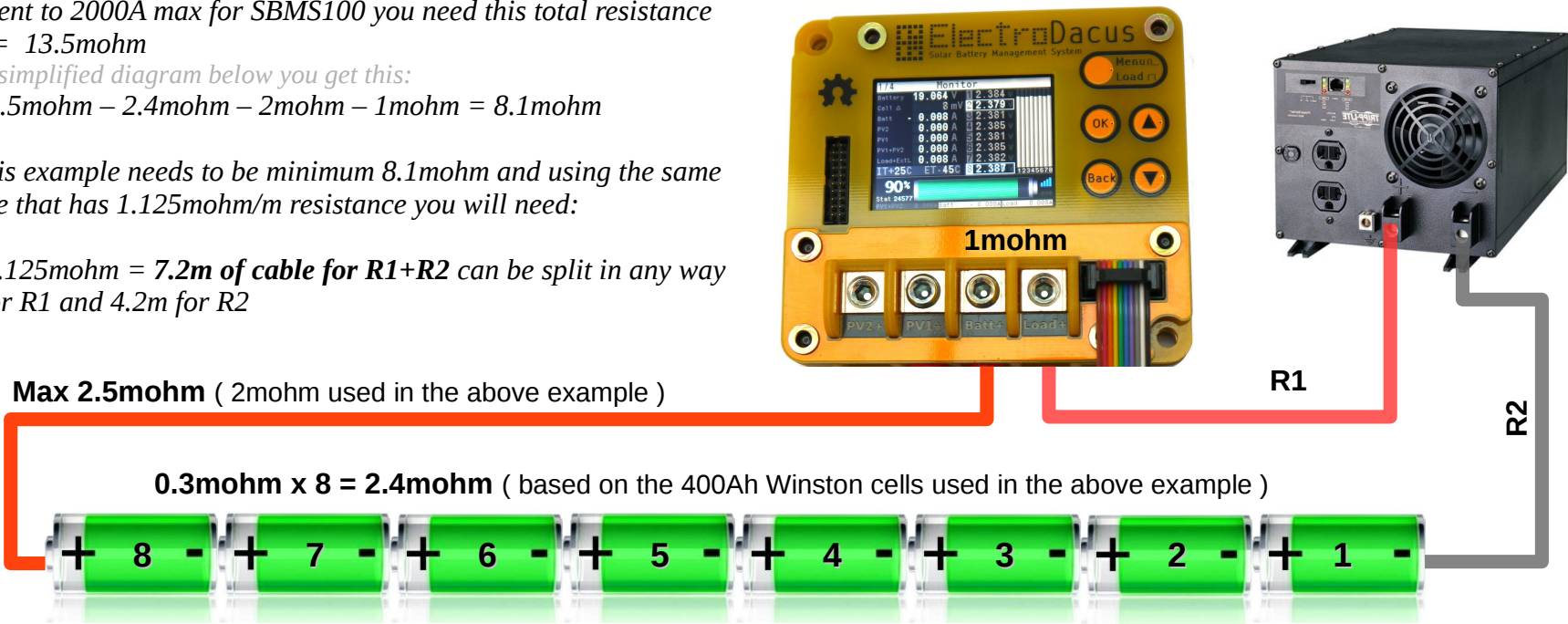

4 External Load

On both SBMS60 and SBMS100 an External Load can be connected allowing large loads of up to 500A to be connected.

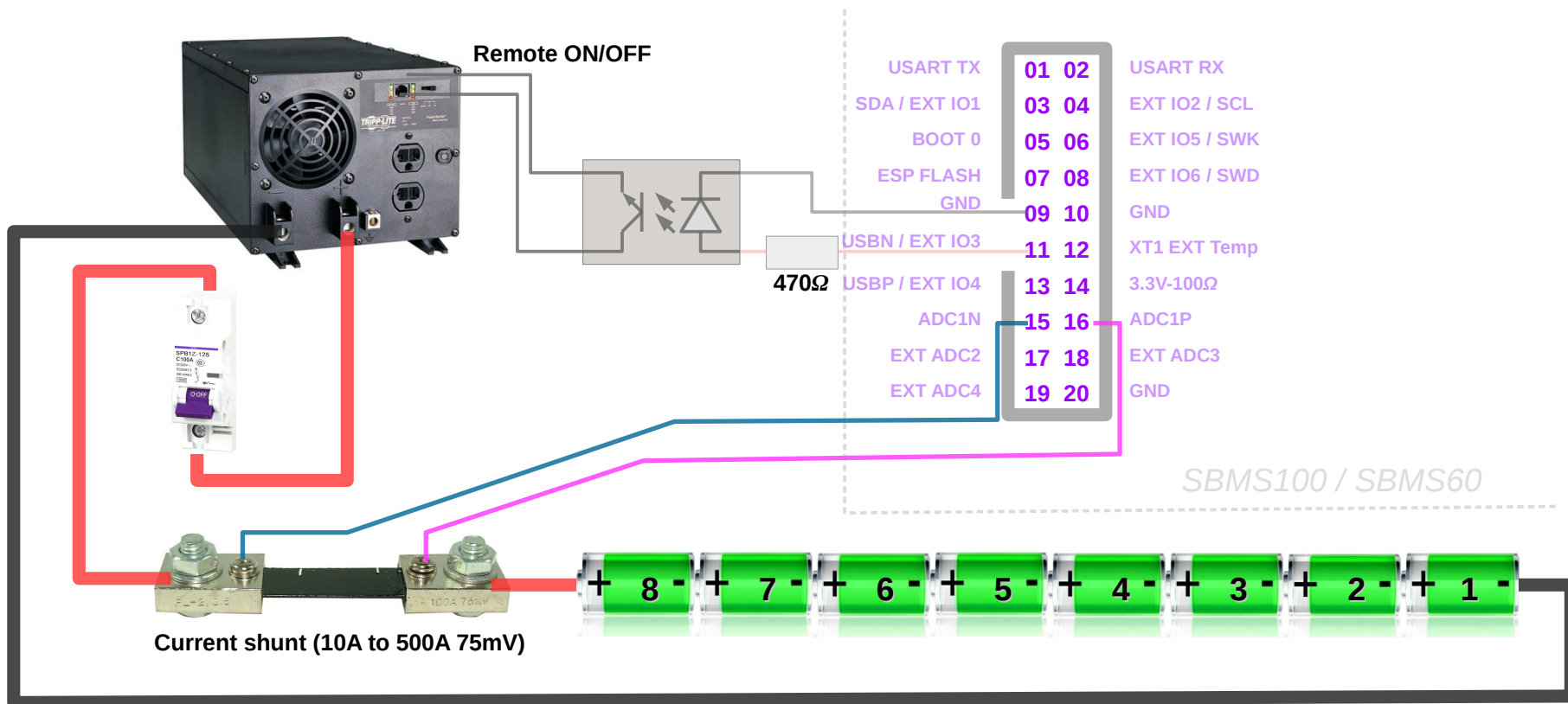

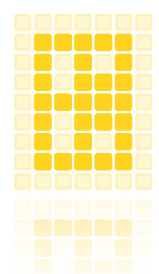

All you need for an external load connection is a 75mV current shunt. Can be 10A up to 500A and the load needs to support remote ON/OFF and optoisolation is required between EXT IO x pin and inverter remote ON/OFF port.

Most large power inverters have a digital remote ON/OFF input signal. The example inverter in the above diagram is the TRIPP-Lite PV2400FC (is a modified sine inverter that I happen to own) that has a 15V signal that if pulled to GND will power ON the inverter and the amount of current when that 15V signal is pulled to GND is around 13mA so most optoisolators will be able to handle that.

You can also use a DC SSR like the SSR 25 DD as explained in this post <https://plus.google.com/+electrodacus/posts/LYyoyG2KwWK>
If you are not using the inverter 24h/day then you can add a normal mechanical switch in series with the optoisolator output so that you can manually turn OFF the inverter. I will do that since I only use the inverter occasionally most of my loads are DC for better efficiency and less noise :).

The EXT IO pins supply 3.3V and up to 20mA can be draw from them. With normal optoisilator with infrared LED the voltage drop on that LED is around 1.2 to 1.3V so about 2V will drop on external resistor you need to add for current limiting (in the above example a 470Ω resistor was used that will limit the LED current to $2V / 470\Omega = 4.25mA$ more than sufficient for the optoisolator).

An appropriate circuit breaker or fuse is also needed for overcurrent protection.

The current sense output from the current shunt gets connected on pins 15 and 16 on the 20pin connector.

The pin16 (ADC1P) will be on the battery positive side of the current shunt resistor and pin15 (ADC1N) on the side going to your external load presumably a DC to AC power inverter as in the above diagram.

The external load will need to support remote ON/OFF capabilities and that will be connected to one of the 4 EXT IO pins.

The EXT IO pin you decide to use (EXT IO3 used in the above example) will need to be programmed in the EXT IO x submenu as type 2 (Low Voltage Disconnect) or as type 4 if you want the load (inverter) to be disconnected when battery gets below a certain SOC level (user programmable).

Another setting you will need to do is in the ADC (ExtLoad settings) submenu where you will be turning the ExtLoad ON and providing the ExtLoad shunt resistance value in [mΩ] so that SBMS is able to calculate and display current correctly.

Example 1) $500A \ 75mV$ shunt will have a resistance value of $75mV / 500A = 0.1500m\Omega$.

Example 2) $75mV / 200A = 0.3750m\Omega$

Example 3) $75mV / 10A = 7.5000m\Omega$.

5 Battery Temperature

It is possible to add external temperature sensor but in most cases not needed and so is optional.

All Lithium batteries require temperature above freezing ($> +5^{\circ}\text{C}$) during charging otherwise they will be damaged.

Best way when possible is to have the battery inside the living space where temperature is ideal for battery operation.

The SBMS is designed to accept a thermistor as temperature sensor connected between pin 12 and one of the GND pins (like pin 10 on the 20 pins connector).

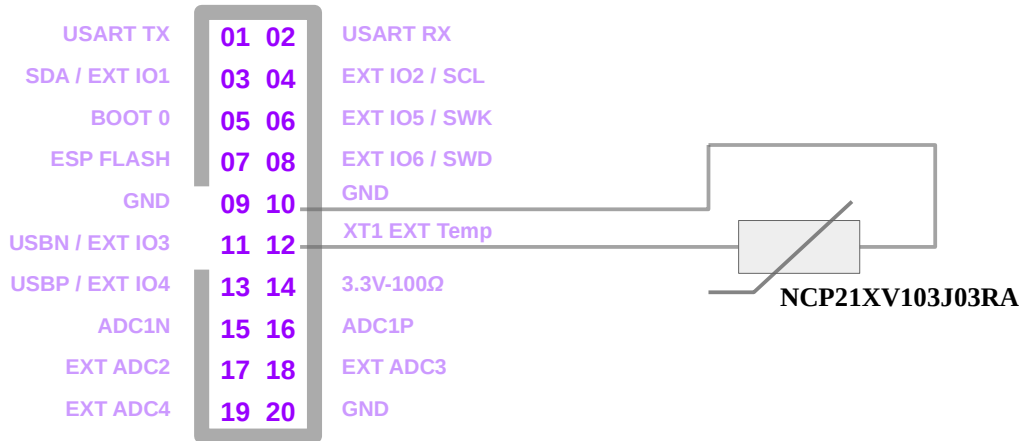

The SBMS is calibrated for a particular 10k Ω thermistor made by Murata NCP21XV103J03RA (this same thermistor type is used internally to measure the power board temperature).

The low and high temperature limits for this external temperature sensor can be set from the Advanced Parameter Setting submenu parameter 29 and 30.

Value is a 12bit binary number and if you use the recommended thermistor the $0^{\circ}\text{C}=3144\text{b}$, $+5^{\circ}\text{C}=3000\text{b}$, $+50^{\circ}\text{C}=1338\text{b}$, $+55^{\circ}\text{C}=1182\text{b}$, $+60^{\circ}\text{C}=1040\text{b}$.

You can see the actual temperature in Monitoring menu and the raw binary value in Diagnostic menu.

6 The 20pin connector

There is a 20pin connector on the left side of the LCD on SBMS and it is used for different functionality described below.

USART TX	01 02	USART RX
SDA / EXT IO1	03 04	EXT IO2 / SCL
BOOT 0	05 06	EXT IO5 / SWK
ESP FLASH	07 08	EXT IO6 / SWD
GND	09 10	GND
USBN / EXT IO3	11 12	XT1 EXT Temp
USBP / EXT IO4	13 14	3.3V-100Ω
ADC1N	15 16	ADC1P
EXT ADC2	17 18	EXT ADC3
EXT ADC4	19 20	GND

01 & 02 USART TX and RX pins are used for the WiFi module so if you want to use the USART for something else then WiFi will be disabled (voltage levels 0 to 3.3V).

03 & 04 This two pins are reserved as I2C port for a future addon to SBMS (Digital MPPT heat controller) and maybe some other future addons.

05 Boot 0 connected to pin **14** will put the STM32F373 microcontroller in programing mode.

06 & 08 This pins have dual function as programmable EXT IO5 and IO6 (0 to 3.3V 20mA max) and as SWK and SWD programing interface for the STM32F373.

07 ESP Flash connected to GND will put the ESP8266 WiFi module in programing mode.

11 & 13 This pins have dual function as programmable EXT IO3 and IO4 (0 to 3.3V 20mA max) and as USB or CAN port not used in the software as of now. USB can probably be used in firmware upload mode for the STM32F373 (not tested).

14 This is a 3.3V supply from the internal DC-DC converter trough a 100Ω series resistor mostly to be used to pull up BOOT 0 pin to enter programing mode.

15 & 16 External current shunt input with a 0 to 90mV input range see page 11 for more details.

17, 18 & 19 Ext ADC inputs 2,3,4 with analog input range of 0 to 1.8V that will be logged in the internal SBMS memory at 2 minute intervals but not used in any automation with the latest firmware version. This are good if you want to log some other analog signals.

09, 10 & 20 GND (same common ground plane for all 3 pins).

7.1 Selecting the battery and PV panels

I always recommend going with 24V since that will be the least expensive option (mostly because of the lower cost PV panels).

There are just two main type of PV cells the 125x125mm (5”) and 156x156mm (6”) cells (6” cells are by far more common and panels made with them are usually lower cost per Watt).

Each cell will have a current output based on surface area of the cell and cell efficiency so the 5” will have around 5 to 6A output with STC (Standard Test Conditions) and the 6” will have a 8 to 9A output in the same conditions.

The output voltage is not dependent of the amount of sun power or cell size and open circuit voltage is around 0.6V to 0.65V / cell and max power point voltage at STC is around 0.5V / PV cell a bit lower as cells get hotter.

The PV cells are connected in series in most solar PV panels and there are just a few standard PV panels with by far the most common in recent years being the 60 cell PV panels rated from 240 to 270W depending on the cell efficiency.

This 60 cell panels made with 6” cells are the most common representing probably close to 80% of the world production and that is why they are the least expensive as in \$/Watt and ideal for 24V LiFePO4 battery charging.

For 12V battery the 32 or 36 cells panels are ideal do to max power point voltage being closer to battery voltage but since they are less common they will cost more per Watt than the 60 cell ones almost to the point that it cost about the same to get a 36 cell 5” panel or a 60 cell 6” panel. The down side will be the size so where space reserved for PV is limited and you want a 12V battery there is no choice other than to get the more expensive 32 or 36 panels.

For battery you will need 4 cells in series for 12V and 8 cells in series for 24V (that is for LiFePO4 most cost effective batteries for stationary energy storage). Any number of cells in parallel will be equivalent to a larger capacity cell but is still easier to have a single large cell than multiple smaller parallel cells. All cells need to be new and the same model/capacity.

In case LiCoO2 or other Lithium Cobalt variants mostly used in consumer electronics and electric vehicles for their higher energy density 7 cells in series will give you the best 24V equivalent and you will select battery Type 2 on the SBMS.

But LiCoO2 will in most cases be more expensive than LiFePO4 over the life of the battery so unless you find like new cells from a damaged EV for less than \$100/kWh as of 2016 is best to get LiFePO4 that is around \$400/kWh new but also lasts at least 4x longer and is safer to use.

7.2 Selecting the battery and PV panels

Another important aspect in sizing the system will be your location and the amount of energy needed.

See three system size example a large a medium and a small system with three different locations.

Ideal charge rate is 0.25 to 0.3C for long life LiFePO4 and as you can see below the selected battery capacity and PV array size respect this rule.

		SBMS100	SBMS60	SBMS60
PV array size STC power (STC current)		3000W (100A)	1820W (60A)	200W (12A)
LiFePO4 battery capacity (voltage)		400Ah (24V)	200Ah (24V)	40Ah (12V)
Min/Max [kWh/month]*	Phoenix/AZ/USA, Dubai/UAE, Alice Springs/Australia	300/360	180/220	18/22
	Regina/SK/Canada, San Francisco/CA/USA, Sydney/Australia	200/320	120/190	12/19
	London/UK, Berlin/Germany, Amsterdam/Netherlands	50/260	30/160	3/16

*Min refers to the worst winter month and that should be the targeted power consumption is you are completely off-grid and there is no other energy source. The numbers are based on the <http://pvwatts.nrel.gov/> online calculator and correlated with my 3 years offgrid experience in Regina/SK/Canada. Panels should be tilted ideally for the best output in winter when is needed most since in summer you will have a lot of excess energy anyway.

There are 3 locations for each group and they are with in 10% of each other so it made sense to group them to keep the table clean.

8 WiFi

Both SBMS100 and SBMS60 include a WiFi module that can be used for remote monitoring. The SBMS acts as an AP (Access Point) and will deliver data to a WiFi enabled computing device that supports a HTML5 capable web browser (a smart phone, tablet or laptop/desktop computer). All you need to do is download and decompress this html file <http://electrodacus.com/SBMS100/SW/SBMS.zip> and copy to your device then connect to SBMS-100 or SBMS-60 named AP and open that file with your preferred web browser.

Notice cell balancing on cell number 5. I had not captured cell balancing in the other photos since cells are well balanced. The “<” symbol after cell voltage indicated cell balancing is performed on that cell.

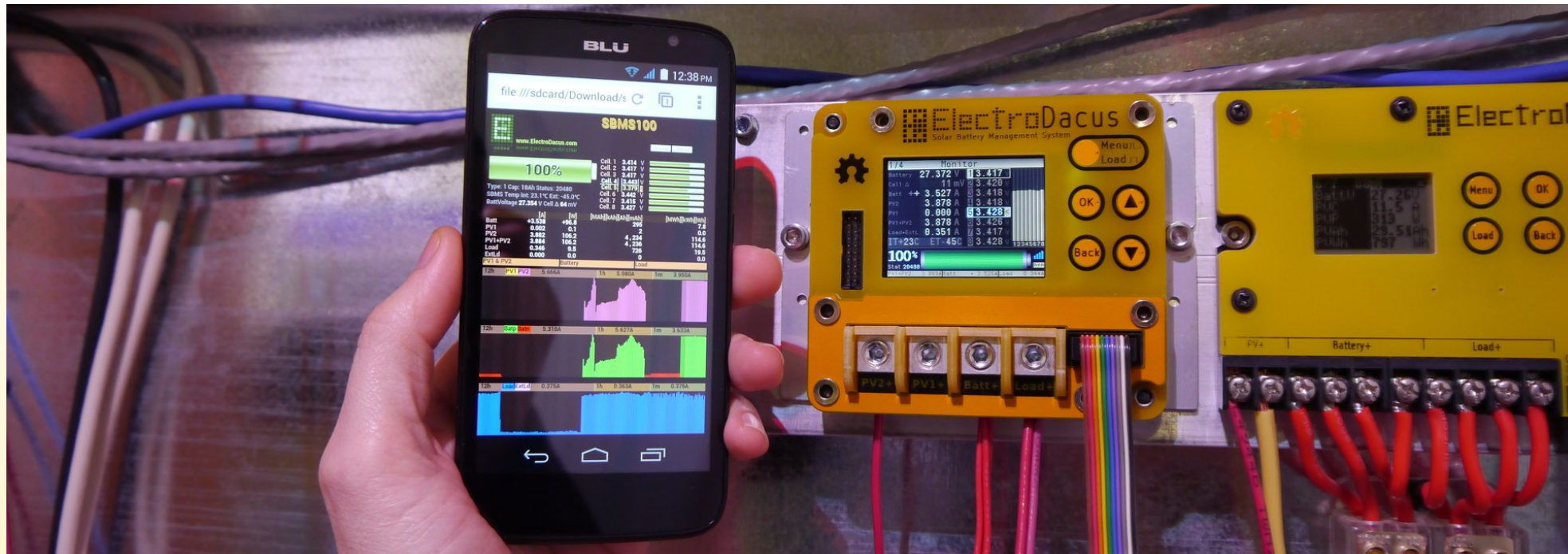

9 Internal data logging

The SBMS has an internal 128Mbit (16Mbyte) SPI Flash memory that can log data at a fixed 2 minute interval.

The memory is capable of storing a full year (12months) of data in a circular type buffer so you always have the last 12 months worth of data in that internal Flash memory.

In order for the data logging to start you will need to set the Date and Time and you will notice the small “mem” symbol in the lower right side of the SBMS LCD being highlighted.

The data is also stored compressed in the memory same base 91 compression mentioned in the WiFi chapter and contains the data sent also over WiFi in the sbms variable.

Here is an explanation of what is contained there and what it is logged in the internal memory.

```
var sbms="YMDHMS%%C1C2C3C4C5C6C7C8ITET+BATPV1PV2EXTAD2AD3AD4ht1ht2ERR"
```

Y-year last two digit (limited to 2090); (sorry if you read this in 2091 I will not expect a software update :)).

M-month

D-day

H-hour

M-minute

S-seconds

%% - SOC 0 to 100%

C1 to C8 - cell voltage in mV

IT and ET - internal and external temperature in hundreds of a degree 0 is -45C and 1449 is 99.9C so you need to subtract 450 from the result and divide by 10 (example 689 as result of the decompression will be $(689-450)/10=23.9C$)

+ - sign for battery charging (+) and discharging (-) used as it is no compression.

BAT - Battery current in mA from -750000mA to +150000mA

PV1 - PV1 input current in mA

PV2 - PV2 input current in mA

EXT - Ext Load current (the use of 10A up to 500A 75mV external current shunt is possible on both SBMS60 and SBMS100 see [page 12](#))

AD2 , AD3 and AD4 - user available ADC inputs the value is the digital output of the ADC.

ht1, ht2 - reserved for power output of the next project (probably still Kickstarter funded) that will be an add-on to SBMS and use the excess PV energy for heating with much larger PV array connection possible up to 15kW with two units and SBMS100.

ERR - this is error code it will contain the information referring to the error flags on the SBMS.

There are 15 Flags (see monitoring page3 on SBMS) not all flags represent an error some are representing normal operation and if you consider this a 15bit binary number each bit representing one flag with “1” highlighted and “0” not highlighted and you start from the top left with OV flag and continue to right and then down to the last flag DFET and consider the OV as the least significant bit and DFET most significant bit then you get this binary number and convert to decimal that will be the value contained in this ERR Status and you can also see this number on the SBMS LCD just under the battery SOC value and also displayed as Status: in the html page.

Uncompressed data and formatted in .csv as it was on SBMS4080 will look like this

```
Y ,M ,D ,H ,M ,S ,SOC,cel1 ,cel2 ,cel3 ,cel4 ,cel5 ,cel6 ,cel7 ,cel8 ,IT ,ET ,-Batt , PV1 , PV2 ,ExtLoad, ADC2, ADC3, ADC4, heat1 , heat2 , ERR  
00,01,31,22,53,47,100,3414,3416,3444,3433,3426,3419,3420,3380,000,000,-002000,000000,000000,000000,000000,000000,000000,000000,000000
```

*This is the javascript function for decompression (you will find this inside the SBMS webpage) function `dcmp(p,s,d){xx=0; for (z=0;z<s;z++){xx = xx + ((d.charCodeAt((p+s-1)-z)-35)*Math.pow(91,z));}return xx;}`*

Where

p - location of the data in the string.

s - size of the data (example year is 1 cell voltage is 2 and PV1 current is 3)

d - the name of the variable in this case sbms.

10 User interface

10.1 Main menu

At power on the SBMS will be on main menu and this can also be access later from any other sub-menu by pressing the menu button on top. The same Menu button has a dual function and if you keep that button pressed (is a touch button so touched) for about 5 seconds you can power ON or OFF the Load and Charge FET's.

You will also be able to see the most important information on the bottom part of the screens (that part is present in most menus).

The bottom part contain SOC level in numeric and graphic form the SBMS status represented by a number, the WiFi and internal data log "mem" symbols. The lowest part will indicate if charge and discharge FET's are active by highlighting or not the PV and Load and you also have the current for PV, Battery and Load.

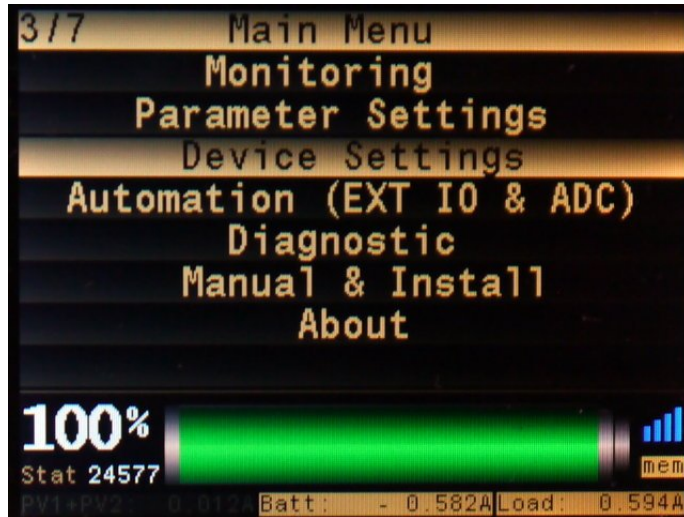

* **SOC (State Of Charge)** indication will be set automatically to 50% (49%) when you connect the SBMS to battery for the first time since SBMS can not guess the state of charge based only on cell voltage.

After the first full charge (on battery type 1 when highest cell gets to 3.53V and EOC flag will be set the battery SOC will jump to 100%) from that point SOC indication will represent the real value.

10.2 Monitoring

The monitoring menu is where you see all the information about the current state of the battery, PV and load.

All is hopefully obvious. The IT (+34°C in the example below) is the internal temperature of the power board and if that gets above +60°C then both the Charge and Discharge will be disabled and will only be enabled after temperature drops below +50°C

ET is external temperature optional since a LiFePO4 will not have any temperature increase working within the 0.3C charge rate and 0.6 to 0.8C discharge rate recommended for Off Grid solar type applications.

The first direction sign for the battery with a darker color represents the ISL94203 current direction detection not as sensitive as the dedicated current shunt and if there is no minimum load or charge in order for the ISL94203 to detect the IC will try to enter in sleep mode after 4.5h of inactivity so you may notice a short one second or less power OFF if you have a really small load and charge not detected by ISL94203 IC.

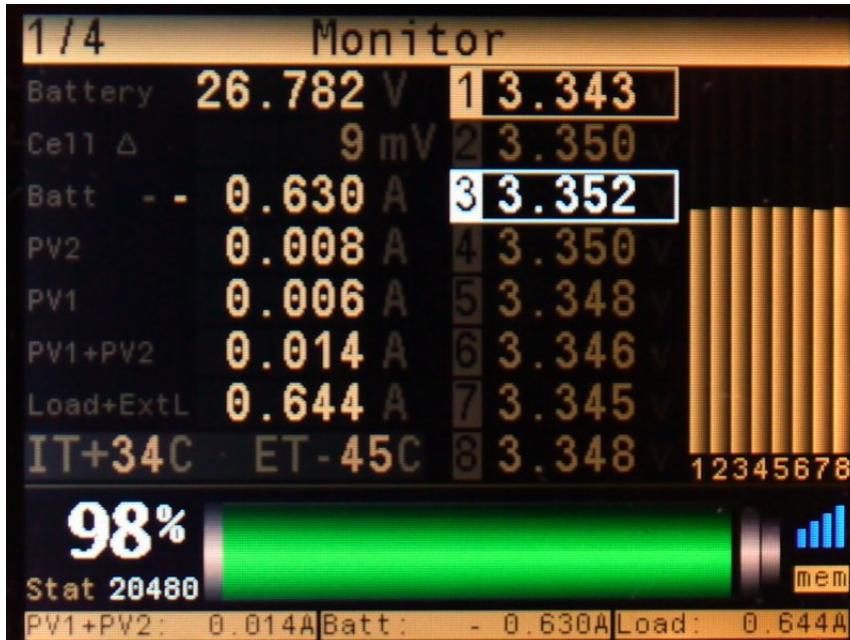

By pressing the OK button while in this menu you will be presented with a small submenu allowing you to change the display from current measured with 1mA resolution to power measured with a 0.1W resolution.

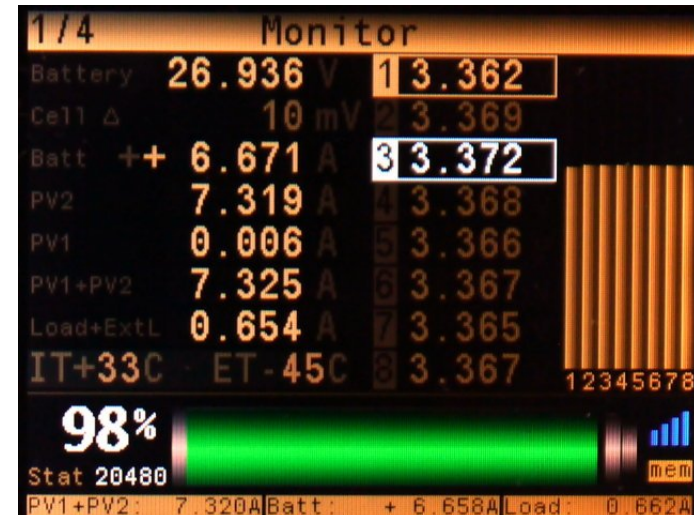

The monitoring menu has a total of 4 pages and the second page of the monitoring accessed by pushing the up key contains the energy counters as you see in the below screen shoot.

The Ah and Wh counters for PV, Battery and Load can be reset by pressing the OK button that will present you with a Reset submenu as you see in the second image allowing reset of each individual counter or resting all counters at the same time by using the last option.

You can get out of this submenu without resenting any counter by selecting NONE or by using the Back touch key.

You can reset this counters every day if you want since there is also a total counter you will be able to find in the About menu and you can read more about that one later in this manual.

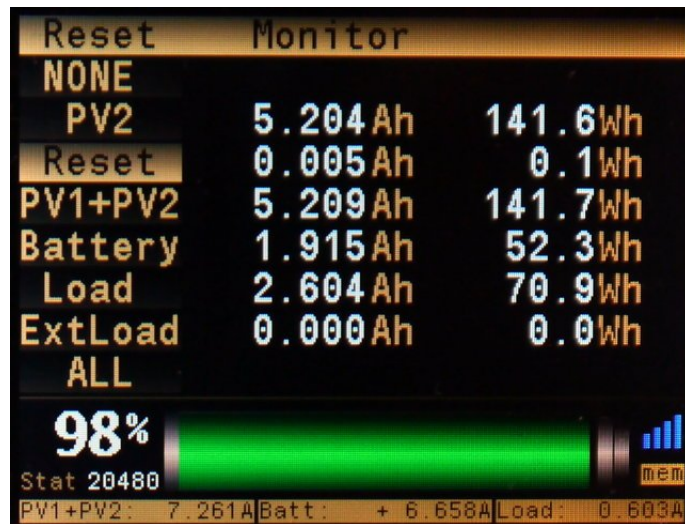
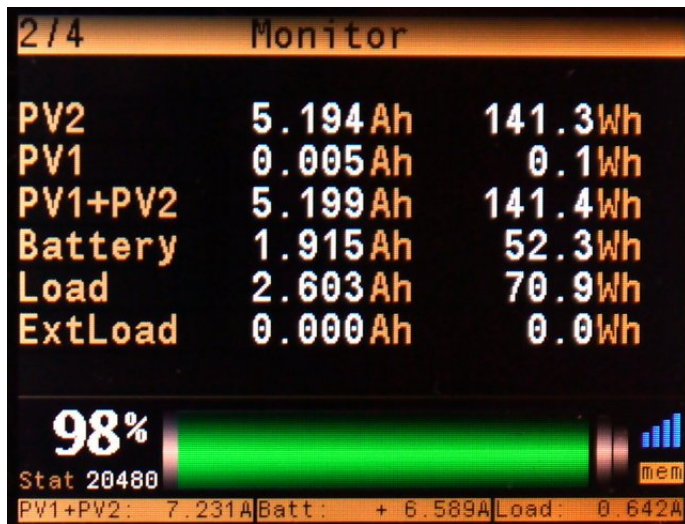

The third monitoring page will display the 15 “error” flags. While I call them error flags they are not all errors and represent normal operation of the SBMS.

CFET and **DFET** show if Charge and Discharge FET's are ON or OFF (if highlighted they are ON). Then when highest cell gets to 3.55V (in case of default battery type 1 settings) the CFET will be turned OFF terminating the charging and the **OV** (Over Voltage) flag will be highlighted but this is normal operation and not an error. Same will be true if battery is getting discharged and the lowest cell gets below 2.8V for more than one second then DFET will be turned OFF and the **UV** (Under Voltage) flag will be highlighted (again normal operation even if you probably do not want to have an empty battery while off grid).

EOC (End Of Charge) is also a normal operation flag and it will be set when the highest cell gets to 3.53V with battery type 1 default settings.

UVLK or **OVLK** is an error since those limits are set lower and higher than UV and OV and it means that the respective mosfet has failed as a short circuit and can not disconnect the PV or Load or you played with advanced parameter settings and used wrong values in there.

COC, **DOC** and **DSC** are also errors for over-current or short circuit and they can be caused by multiple conditions.

OPEN (open cell wire) is also an error indicating that you have a bad connection to one of the cell monitoring wires while **CELF** (cell fail) means that one of the cells has a voltage below what is acceptable and may be do to a bad cell to cell power connection or a defective cell with high internal resistance.

LVC is also an error and means that one of the cells has a voltage so low that normal charging is not allowed (you can manually charge that cell with a small current and see if it can be recovered).

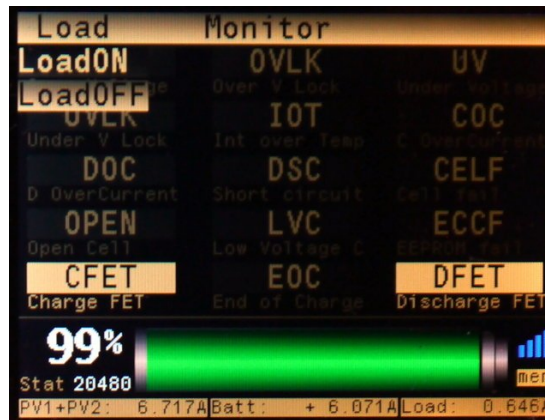
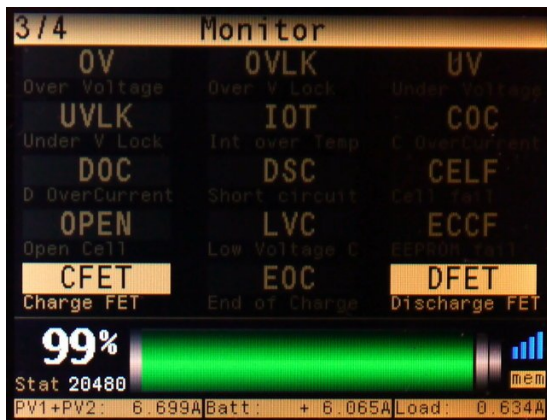

The last monitoring page (page 4) will give you a graphical representation for current or power energy graphs. To select between the current and power energy graphs you push the OK button that will bring a submenu with the first to options being current or power.

There are 9 mini graphs from top to bottom you have PV, Battery and Load graph and from left to right you have last 12h, last 1h and last one minute energy graphs.

All this graphs can be zoomed in by using the OK button and selecting one of the 3 options PV, Battery and Load.

The mini graphs are auto scaling and the peak in each graph is represented by a number displayed on the top right corner of the graph.

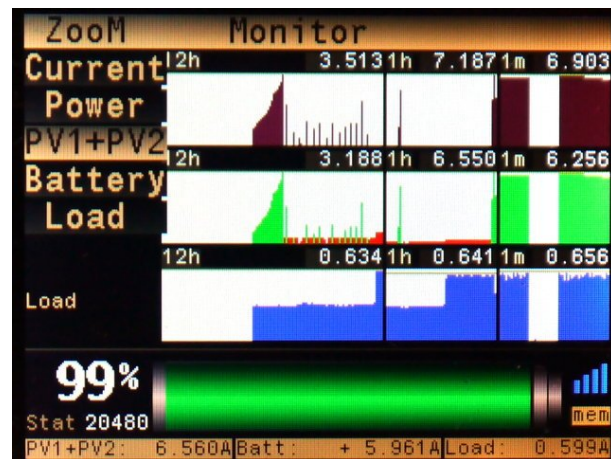
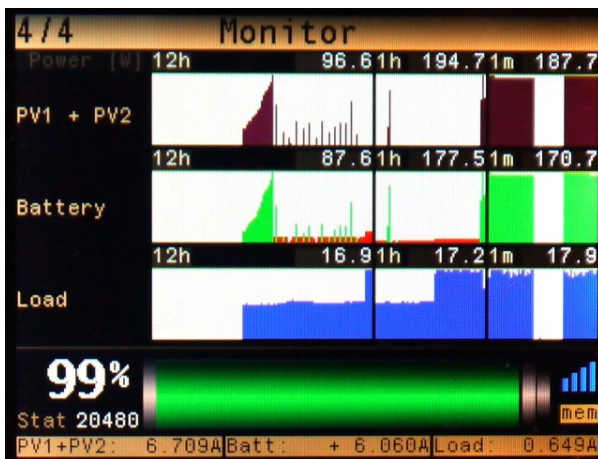
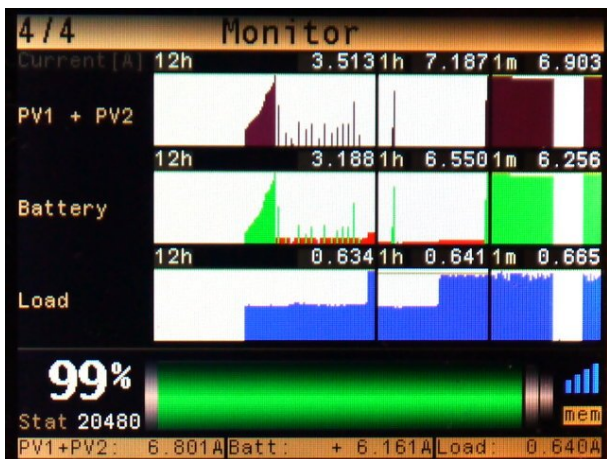

Here you can see some of the zoomed graphs they will show a larger time range than the mini graphs so you see the last 24h the last 4h and the last 4 minutes and you can select that again by pressing the OK button and being presented with a submenu. In this zoomed graphs you also have the possibility to use a cursor to make measurements on the graph and the cursor can be moved with the up and down keys.

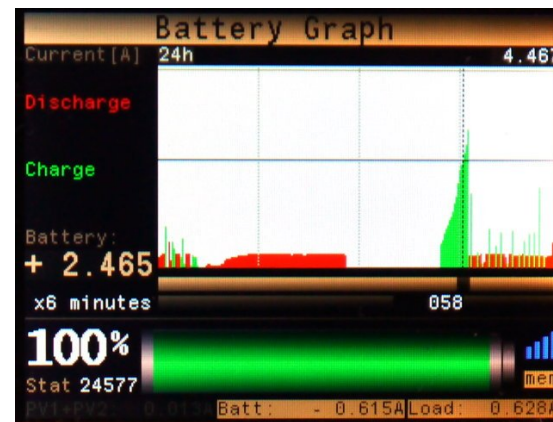
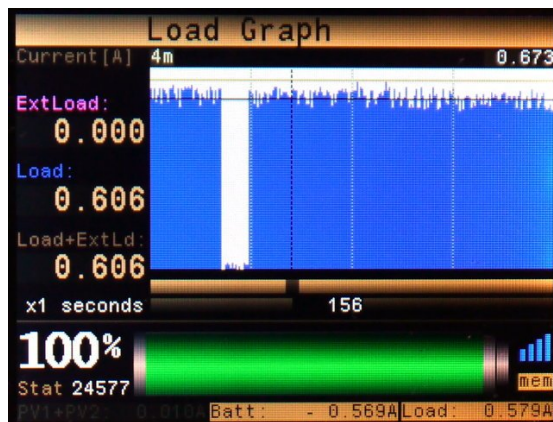
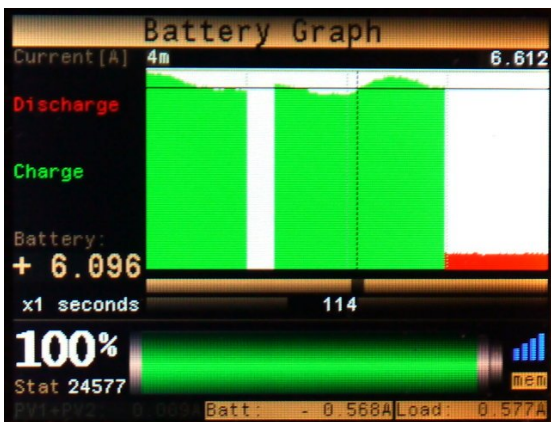
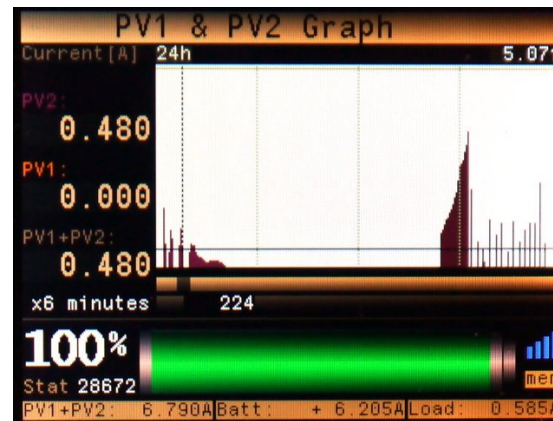
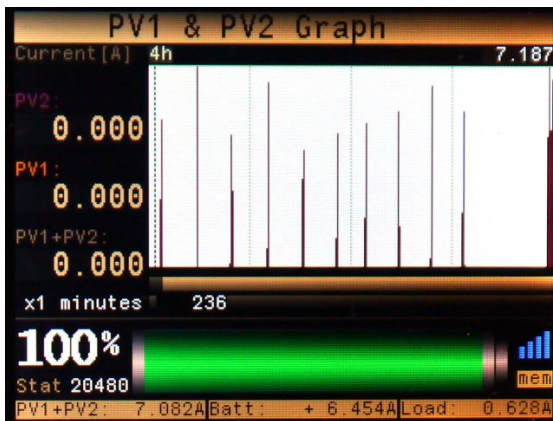
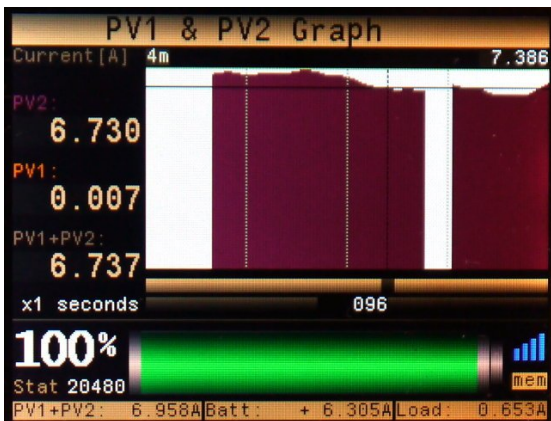

10.3 Parameter settings

The parameter settings menu is important and the first you will use when you install the SBMS since you need to select your battery type. Fortunately the settings are simple since all you need to do is select battery type probably type 1 “LiFePO₄” since that is the most cost effective battery for stationary energy storage do to is long cycle life compared to other type of lithium batteries and also one of the safest batteries. Then next thing you select is the number of cells probably 8 cells or in some case 4 cells if just a 12v equivalent system is needed and the circuit diagram on the bottom will auto update to show you how to make the connections for different number of cell configurations starting with a minimum of 3 cells and up to max 8 cells.

The third and last setting is the battery capacity in Ah and this is needed so that SBMS can know to calculate the real SOC (State Of Charge) for your battery pack.

In the example below is my small 20Ah A123 system battery but the settings is set at 18Ah because that is the real capacity I measured and using that will give me a more accurate SOC calculation.

Then just push the Store Parameters button and a green progress bar will show up briefly (about 2 seconds) indicating that data is written to the ISL94203 EEPROM and for this to take effect a power cycle will be needed as explained in install instructions.

**the parameters can not be set while SBMS is powered by USB you need to be connected to a battery to use Store Parameter button.*

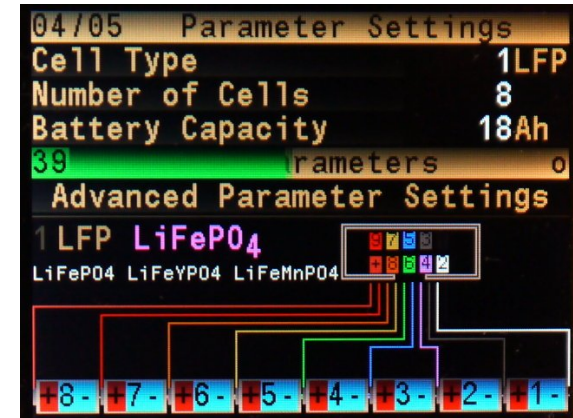
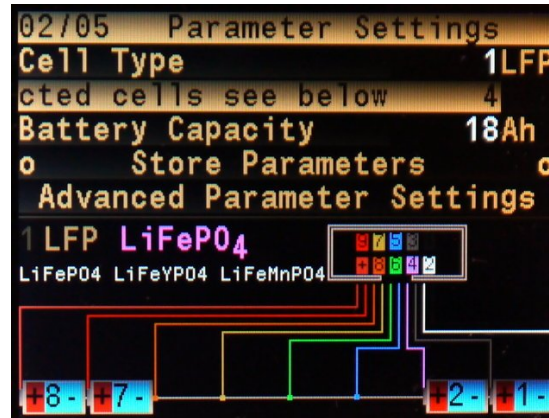
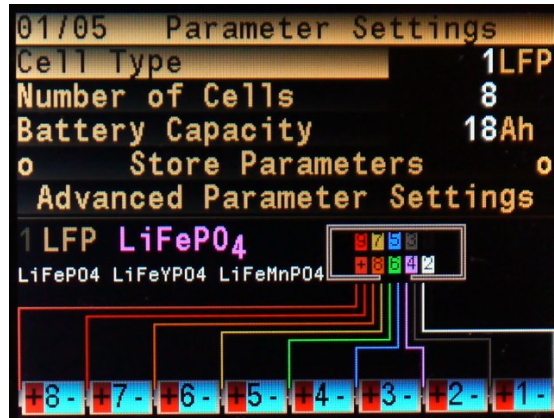

10.3.1 Advanced parameter settings

The advanced parameter settings contains over 30 parameters related to battery charging and discharging and for most users this is not something they will want to mess with :) . If you think you have strong knowledge about how the Lithium cells should be charged then just read the build in scrolling help explaining each parameter.

The default parameters that I carefully selected for long battery life are good for most cases. Unless you want something specific and you understand the implications of changing this settings is better not to change settings in this menu.

If you do change one parameter look also at the rest of them since there are probably related parameters that need to be changed also in order for the charge and discharge to work correctly.

When entering from the main menu in the Parameter setting the parameters displayed in both simple and advanced are the one currently set in the ISL94203 when you select a Cell Type all the values will be set to default.

**the parameters can not be set while SBMS is powered by USB you need to be connected to a battery to use Store Parameter button.*

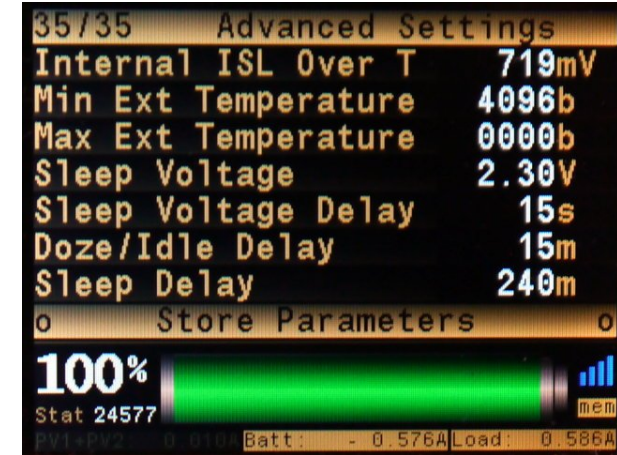
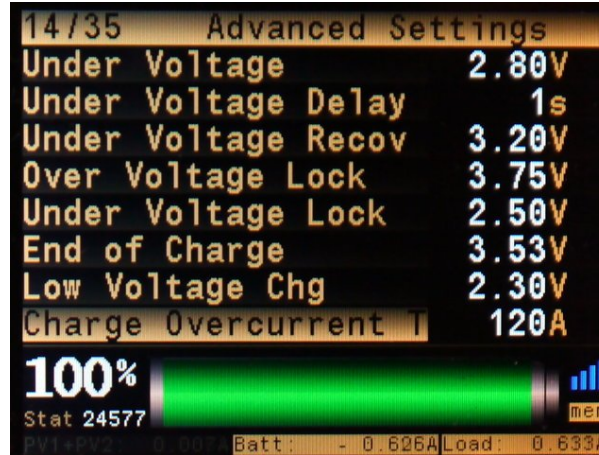
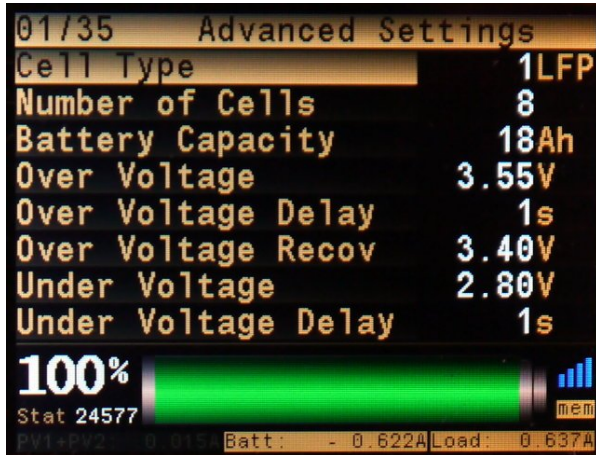

10.4 Device settings

10.4.1 Time & Date

To enable internal data log you need to set the time and date. While in the time and date menu the data logging is disabled but once you get out of that menu after you set the date and time the internal data log is enabled and you will see the “mem” symbol under WiFi symbol highlighted.

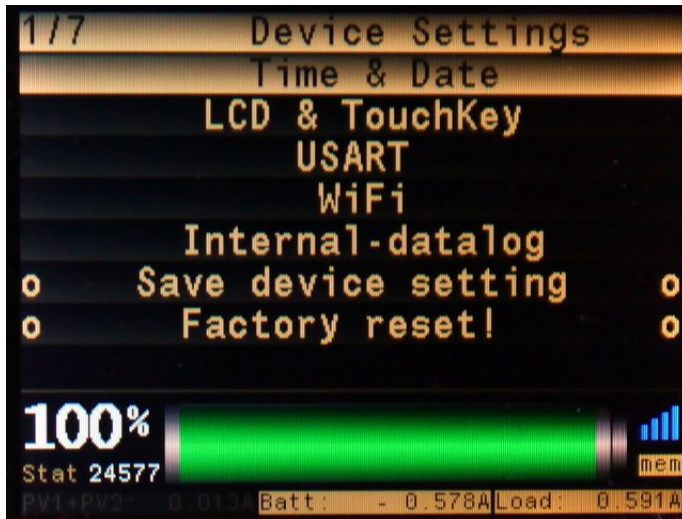

10.4.2 LCD & TouchKey

The LCD & TouchKey menu has 4 settings.

Back light level has a value from 1 to 32 and will affect the brightness of the LCD's LED back light with 1 the lowest setting and 32 the highest. The LED current limiting is an analog constant current level no PWM dimming is used so there will be no flicker.

Menu color allows you to change the color scheme from 0 to 9 with number 2 set as default. A large percentage of people especially men are color blind with most of them not being able to see red, green or both and in that case the default yellow/orange color is quite bad (is not so high contrast even for people that see all colors) and you should probably select the light blue number 9 for more visibility or try the other colors to see what looks best for you.

Back light time out is the amount of time in minutes until the back light level will enter a low power mode where level will be set to 5 if no keys are touched in this interval of time. Setting a lower level or even turning off the LED will not save any significant amount of power so I decided to have level 5 as low power mode. If set to zero it will never enter low power mode.

Key lock time out is the amount of time in minutes until the capacitive touch keys will be locked and to unlock you will need to push 3 keys in the following order OK,UP,DOWN (there will be on screen instructions about this). If set to zero keys will never get locked.

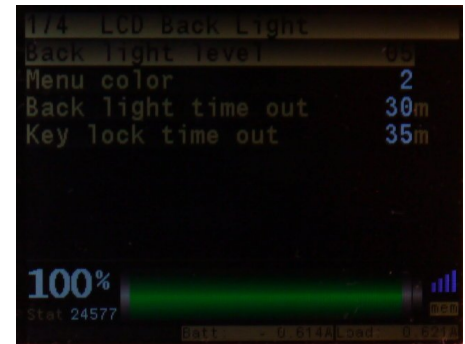

10.4.3 USART

The USART RX and TX pins are available on the 20 pin connector for the user but they are also used by the WiFi module so if you want to use the serial port the WiFi can not be used.

When you set the USART data log on 1 the WiFi will automatically be deactivated. You may also want to set the bit rate lower since that default 921.6kbps is used by the WiFi module.

The log interval represents the interval at witch the compressed log data will be sent over automatically (no request is necessary). You just need a device reading and storing the data.

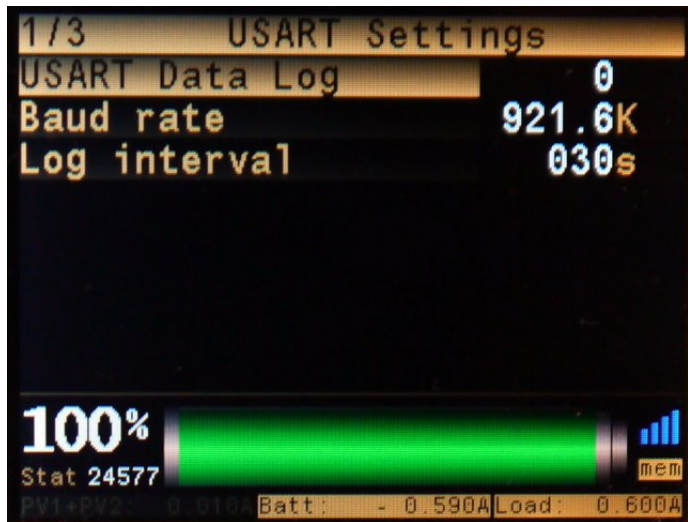

10.4.4 WiFi settings

The SBMS has an internal WiFi module based on the popular ESP8266.

The WiFi is set as an AP (access point) and you can select the channel, the AP name (useful if you have more than one SBMS) and you can also set a password if you want there is none by default. The lower part is the raw response of the module to CWSAP command if WiFi module is ON. Disabling the WiFi will power down the module and that is the best way to save power (not that is needed with the huge battery capacity used in offgrid).

Check [page 18](#) for more details on the WiFi

```
1/6 WiFi Settings
> WiFi enable or (dis) 1
WiFi AP Channel 05Ch
AP name SBMS- 101
Pass On(1) / Off(0) 0
AP Pass part1 00000
AP Pass part2 00000BMS
+CWSAP: "SBMS-101", "0000000000BMS", 5,0 OK
WiFi ON
100% Stat 24577 mem
Batt: - 0.586A Load: 0.595A
```

10.4.5 Internal data log menu

You can download one month at a time worth of data from the internal 128Mbit (16Mbyte) internal SPI Flash memory that can store the last 12 months worth of data.

The progress that normally takes around 40 to 50 seconds is shown as a matrix of small rectangle each representing one of the 744 hours in a full month. The ones with a different color represent a transmission error but that will be “corrected” so there will be no missing data but there may be some data sent twice still not a problem since no data is missing.

For more details on how to use this to download data over WiFi check [page 20](#)

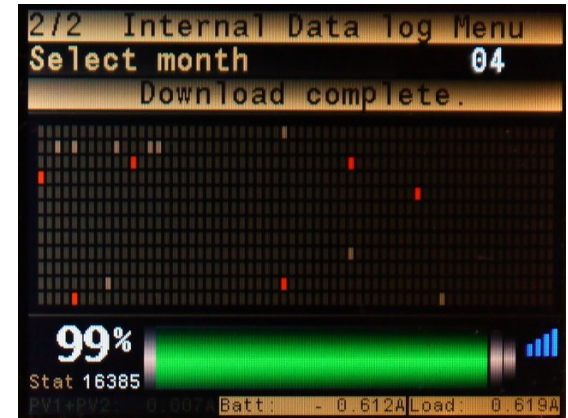
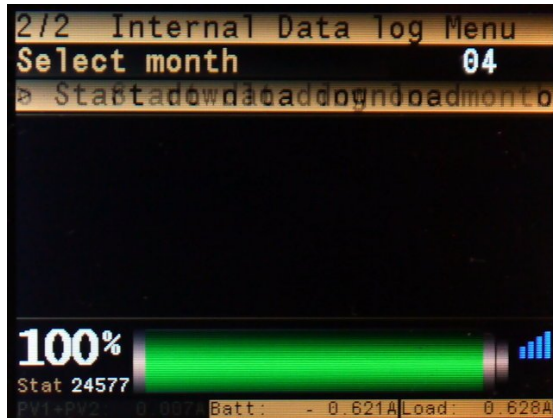

10.4.6 Save device settings & Factory reset

There are two buttons one that will save all the settings made in the Device Settings menu except for the time and date settings and all the settings in the Automation menu. After the power to SBMS is removed this data will be in the internal Flash memory so they will be loaded at power up. The Save device settings will just give you a confirmation that data were saved but the Factory reset (that actually just deletes this saved settings so that default are loaded initially) needs also a confirmation. So for Factory reset you need to push OK once then it will ask to confirm by pushing the OK button again.

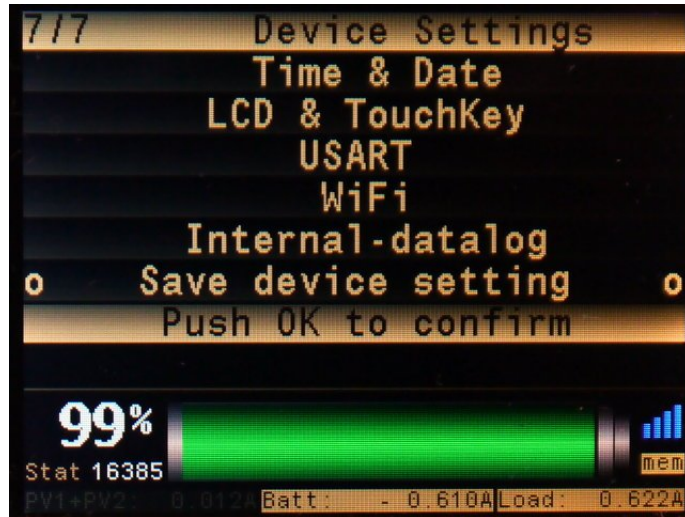

10.5 Automation (EXT IO & ADC)

In this menu you can see the 20pin connector pinout and you can set the 4 EXT IO pins as one of the 5 types including the possibility to change state when battery SOC is above or below a user defined SOC.

In the ADC settings you can set ON/OFF and external load see [page 12](#) for more details and you can also manually calibrate the internal current readings by fine adjusting the internal current shunt value. The default should be close enough in most cases.

The current sense amplifiers used for PV and ExtLoad can have a positive or negative offset. In case the offset is positive the auto-calibration done when SBMS powers ON can be done correctly. Since ADC inputs (with the exception of battery ADC) are single ended and can only see a positive voltage as reference to ground it will not be able to see a current sense amplifier negative offset (offset has to do with manufacturing tolerances) and a manual correction may be necessary. The offset is usually very small and will translate in just a few mA worst case 300mA.

You will notice that at a small current there will be no reading and after current is above the offset level the reading will exist but it will have the subtracted offset value. If you add that offset in here the reading will be more accurate since it will include that negative offset.

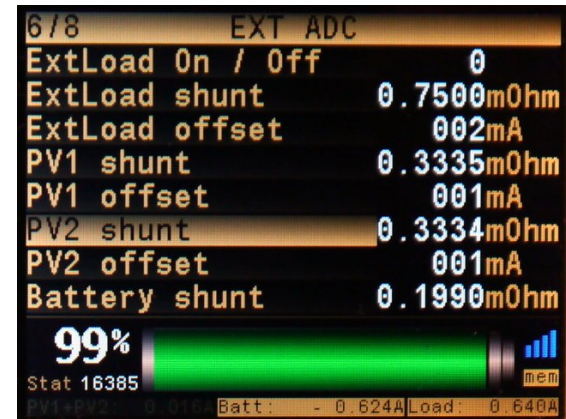
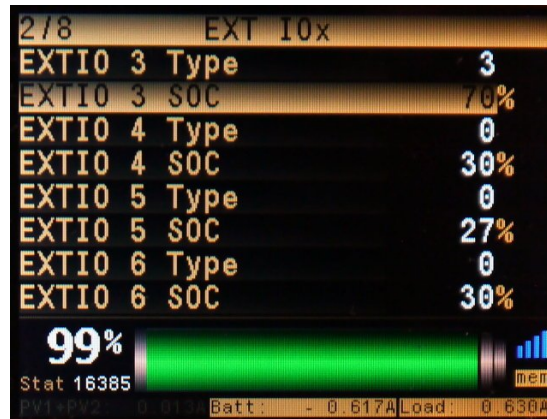
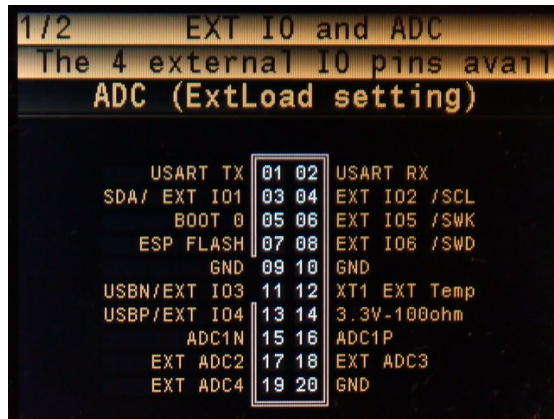

10.6 Diagnostic

This is just useful for development there are some raw ADC readings and the content of the ISL94203 memory again as raw data. Since I used this during development I decided to leave in the final release but is not useful for most people.

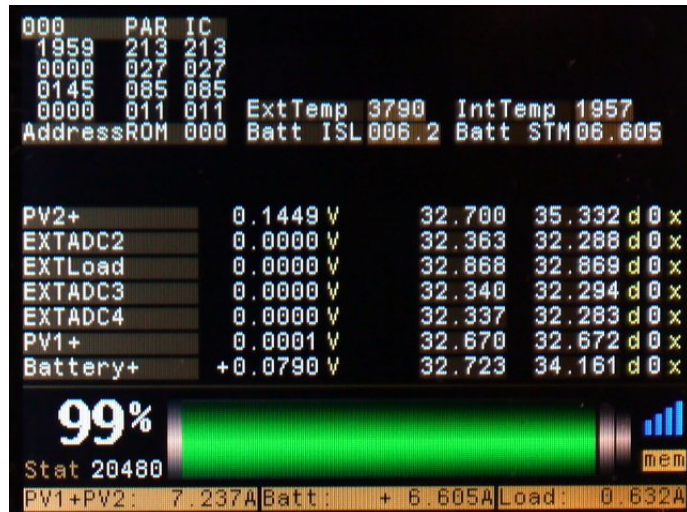

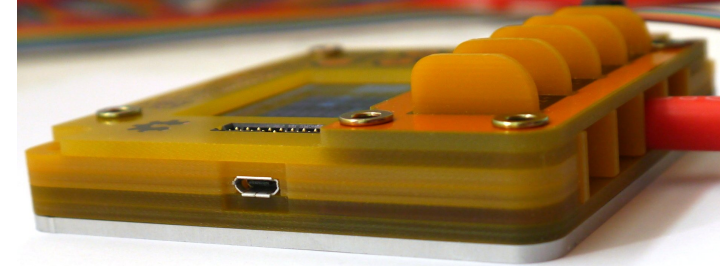

10.7 Manual & Install menu

The SBMS has built in install instructions and a basic manual so if you do not have this pdf manual but have access to SBMS and an micro-usb cable you can read the install instructions from the SBMS LCD.



1/8 Install steps
Step 1

Connect the Batt+ power connector to battery positive terminal with a max 2m (6ft) of 16mm² (#6AWG) flexible copper wire with 200C silicone insulation check manual for more details about the recommended cable. Make sure this is the first connected and last to be removed.



100%   

Stat 20480

PV1+PV2: 7.168A | Batt: + 6.534A | Load: 0.634A

01/19 Manual
Table of Contents

Specifications.....02
Thermal management.....05
Cable selection.....10
External Load.....13
External Temperature.....17

100%   

Stat 20480

PV1+PV2: 7.138A | Batt: + 6.476A | Load: 0.662A

10.8 About menu

The about menu offers some important information. On top of the expected model number, hardware and software version you also have an energy counter for PV1, PV2 and Battery that are separate from the resettable counters on the monitoring menu.

This counter has no option to be reset and the counter value will be saved once every 24h in the internal flash memory so the value will be there even after a power cycle.

There is also an UP Time counter that will count the number of hours the SBMS was powered.

This screen capture below is from the SBMS100 installed on my small A123 20Ah 24V battery connected to a single 260W PV panel and as load there are two 5W LED lights that work 12 to 16h/day so not much energy was used in those 1391 hours since it was installed.

Total energy used was 11.876kWh with a part of it was used directly by load but also a significant part 8.479kWh was used from the battery.

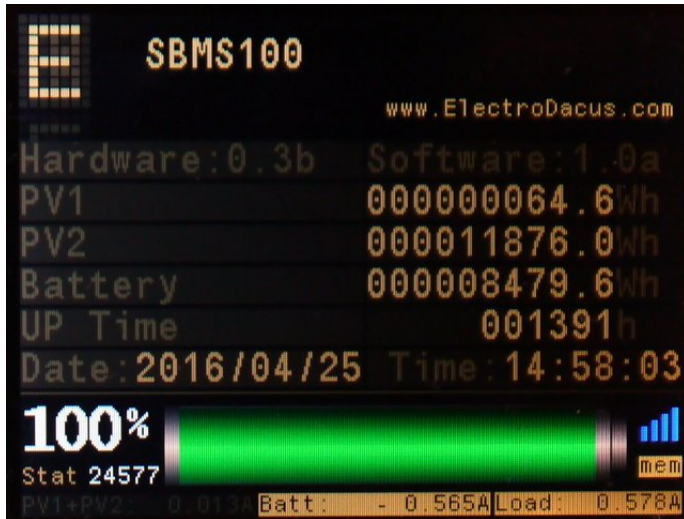

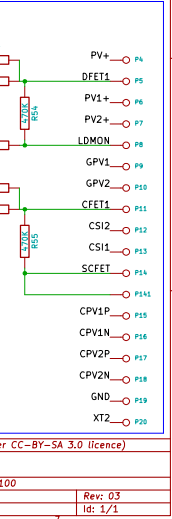
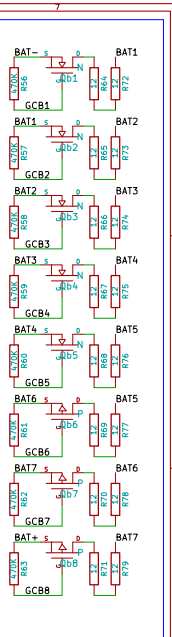
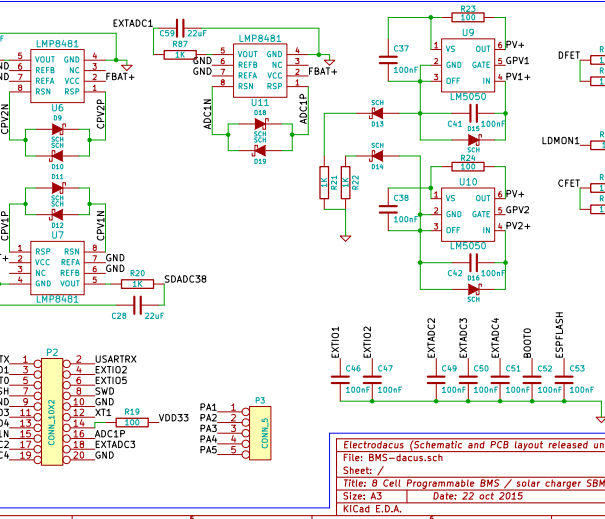
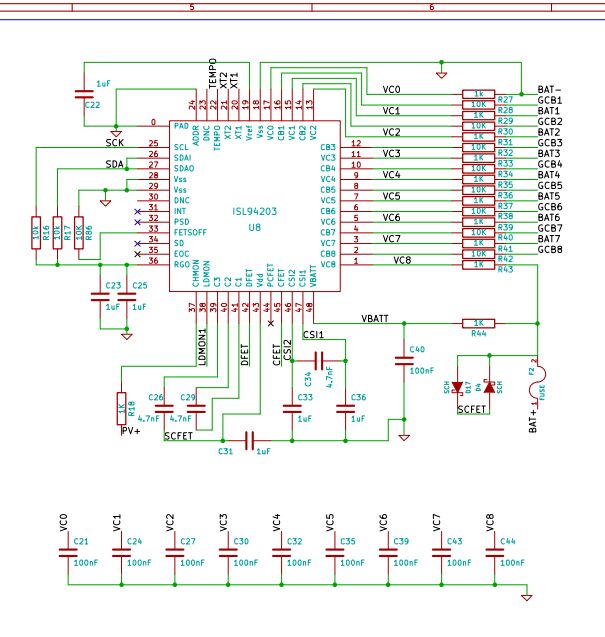
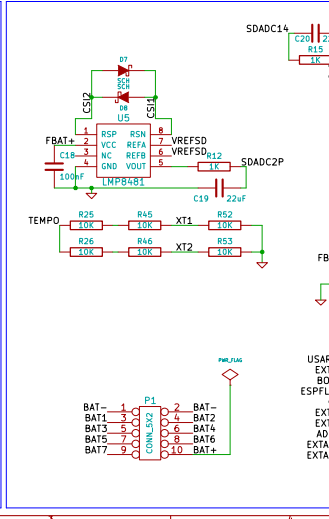
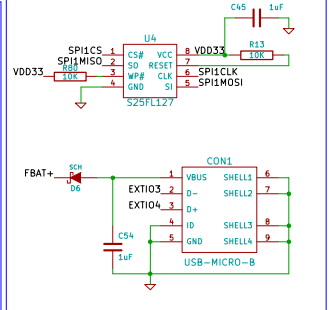
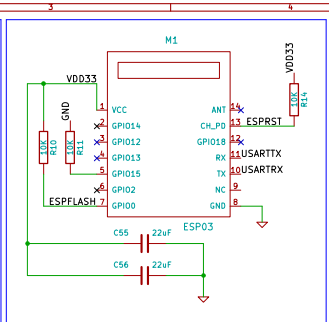
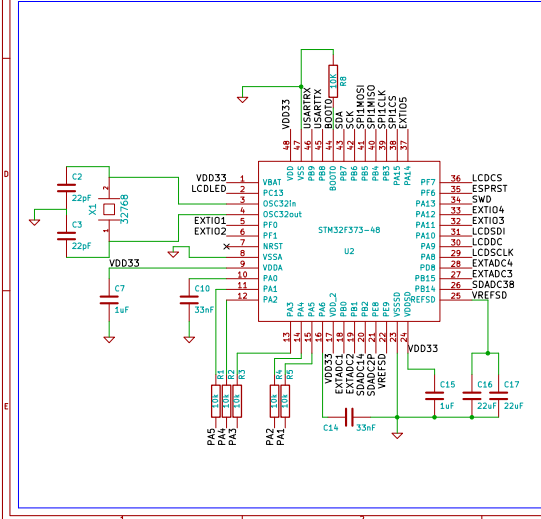
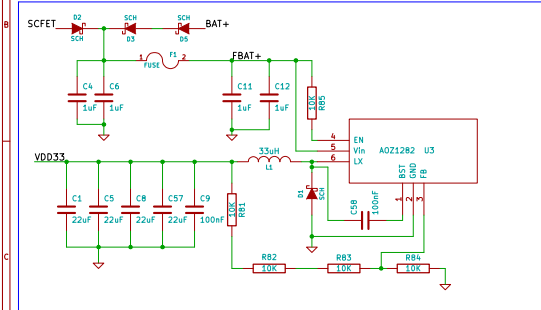
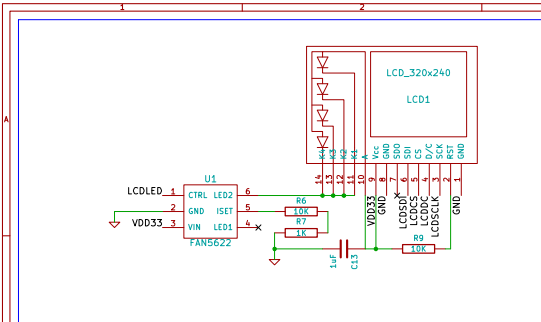

Electrodacus (Schematic and PCB layout released under CC-BY-SA 3.0 licence)	
File: BMS-gacus.sch	Sheet: /
Title: 8 Cell Programmable BMS / solar charger SBMS100	
Size: A3	Date: 22 oct 2015
KiCad E.D.A.	Rev: 03
	Id: 1/1

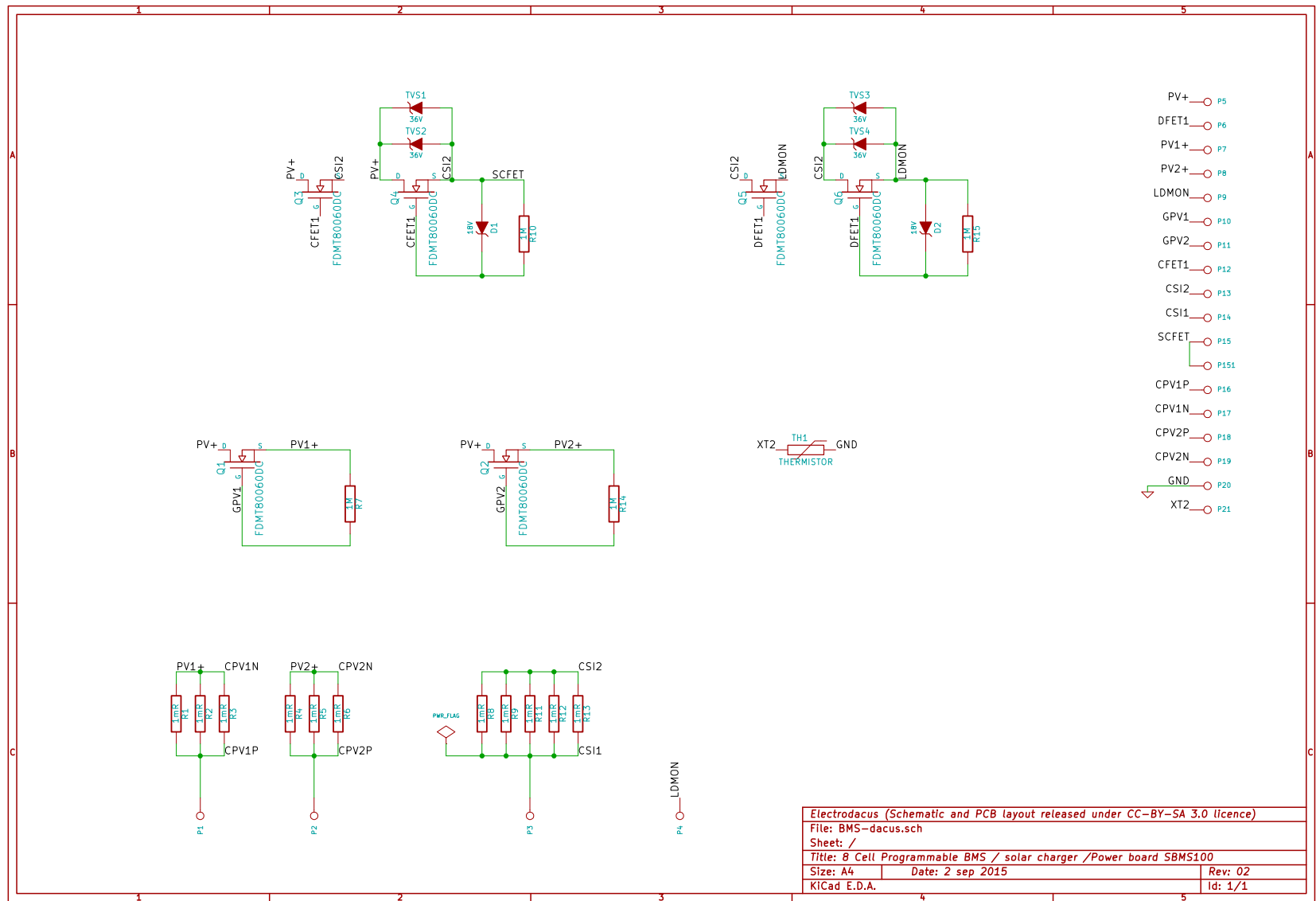
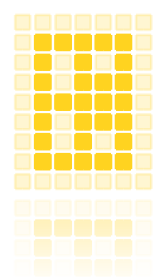

Electrodacus (Schematic and PCB layout released under CC-BY-SA 3.0 licence)		
File: BMS-dacus.sch		
Sheet: /		
Title: 8 Cell Programmable BMS / solar charger /Power board SBMS100		
Size: A4	Date: 2 sep 2015	Rev: 02
KICad E.D.A.		Id: 1/1